

ICON X



user manual



**⚠ WARNING:** This is not a toy. Misuse may cause serious injury or death. Eye protection designed specifically for paintball must be worn by the user and persons within range. Recommend 18 years of age or older to purchase. Persons under 18 years of age must have adult supervision. READ OWNER'S MANUAL BEFORE USING.

Rules of Safe Marker Handling

1. Treat every marker as if it were loaded.
2. Never look down the barrel of a paintball marker.
3. Keep your finger off the trigger until ready to shoot.
4. Never point the marker at anything you don't wish to shoot.
5. Keep the marker on "safe" until ready to shoot.
6. Keep the barrel blocking device in/on the marker's muzzle when not shooting.
7. Always remove paintballs and propellant source before disassembly.
8. After removing propellant source, point marker in safe direction and discharge until marker is degassed.
9. Store the marker unloaded and de-gassed in a secure place.
10. Follow warnings listed on propellant source for handling and storage.
11. Do not shoot at fragile objects such as windows.
12. Every person within range must wear eye, face and ear protection designed specifically to stop paintballs and meeting ASTM standard F1776.
13. Always measure your marker's velocity before playing paintball and never shoot at velocities in excess of 91.44 meters (300 feet) per second.

**TABLE OF CONTENTS:**

Page	Topic(s)
2. ....	Welcome
	Warranty Information
3. ....	Initial Assembly
	Attaching Propellant Source
	Attaching Feeder/Hopper
4-5. ....	Exploded Diagram
	Parts Key
6. ....	Loading Paintballs
	Chronographing
	De-Gassing
7. ....	Maintenance
8. ....	Storage
	Trouble Shooting Guide
9. ....	Warranty Registration



**Welcome** . . . Thank you, for purchasing this Icon X Paintball marker. The Icon X represents the culmination of a great deal of research and development focused on creating a marker with outstanding performance and durability at a reasonable price. The aircraft grade aluminum upper receiver with a quick strip pin, ambidextrous cocking, stainless steel hose, bottom line, drop forward and dual finger trigger are all features usually available on much pricier markers or only through a great deal of after-market expense. We believe that the affordability of a reliable, feature packed marker will improve your playing experience.

Play hard, play safe, play to win!

## WARRANTY INFORMATION

### Standard Warranty:

The manufacturer warrants to the original customer that this product is free from defects in material and workmanship under normal use and service for a period of 90 days from the original date of purchase by the initial owner/purchaser. The manufacturer agrees to repair or replace (at its discretion) any product within a reasonable period of time. This warranty does not cover: o-rings, scratches, nicks, normal wear and tear of parts, any modifications or normal fading of anodizing or damage caused by dropping or hitting of the product. This warranty shall not apply if it is shown by the manufacturer that the consumer caused the defect or malfunction because of misuse. This warranty only covers original factory parts. Any modifications or tampering of original factory parts will not be covered by this warranty. Warranty work can only be conducted by the manufacture technicians and or authorized technicians. If product needs to be repair, package it carefully and send it together with your name, address, phone number and a brief description of the malfunction to:

Paintball Solutions  
570 Mantua Blvd  
Sewell, NJ 08080

### Extended Warranty:

By returning the enclosed warranty registration card or registering your warranty on-line at [www.PaintballSolutions.com](http://www.PaintballSolutions.com), within fifteen days of purchase the warranty will automatically be extended for an additional year.

Numbers shown in parentheses following part names correspond to the numbers on the Parts key located on the centerfold pages of this manual.

## Initial Assembly

1. Screw Barrel (23) hand tight into the Main Body (34).
2. Screw Velocity Adjuster (12) into the Rear Plug (24) approximately two complete turns.
3. Place Barrel Blocking Device on/into the end of the Barrel (24).
4. Push the safety (41) into the "safe" position (push from left to right when looking down the sights).

## Attaching Propellant Source

1. Confirm that Barrel Blocking Device is properly installed and the marker is on "Safe".
2. Cock the marker by pulling the Bolt (28) in the rearward direction until it "clicks" into place. This compresses the Main Spring (2) and allows the Cup Seal (7) to properly seat.
3. Point the marker downward and in a safe direction.
4. Place the leading end of the propellant cylinder threads into the threaded interface of the Tank Adapter (14).
5. Without pushing, twist the propellant cylinder in a clockwise direction and allow the cylinder threads to "draw" the cylinder into the ASA. DO NOT force the cylinder which could cause cross threading.
6. Screw the propellant cylinder completely in until it is firmly seated.

## Attaching Feeder/Hopper

Due to the high rate of fire capability of this marker, we highly recommend the use of a motorized hopper such as the Diablo TSA or Empire Reloader.

1. Confirm that Barrel Blocking Device is properly installed and the marker is on "Safe".
2. Loosen both thumb screws on the Straight Elbow without removing them.
3. Place the smaller opening of the Straight Elbow over the top of the Vertical Feed Tube (11) and tighten the lower thumb screw until tight.
4. Press neck of Feeder/Hopper into the top of the Straight Elbow until completely seated.
5. Orient the Feeder/Hopper so that the lid is facing the rear of the marker and the Feeder/Hopper is parallel to the Main Body.
6. Tighten the upper thumb screw on the Straight Elbow until the Feeder/Hopper neck is firmly held in place.

### Loading Paintballs

The performance of your marker is directly related to the quality of paintballs used. We highly recommend Diablo paintballs to give you satisfaction and success on the playing field.

1. Confirm that Barrel Blocking Device is properly installed and the marker is on "Safe".
2. Point marker in a safe direction and load paintballs in the Feeder/Hopper. Be sure to leave some room in the hopper for the balls to feed properly.

### Chronographing

Never operate your marker without first checking the velocity and confirming that you are firing below that required on the field of play. At no time should the marker fire paintballs in excess of 300 feet per second. Higher velocities are not only potentially dangerous, they often result in a substantial increase in paintballs broken in the marker.

1. Confirm that Barrel Blocking Device is properly installed and the marker is on "Safe".
2. Using a 5/64 hex key (not provided) make sure the Velocity Adjuster Set Screw (12B) is backed out without removing it.
3. Make sure that you and anyone within range is wearing eye protection designed specifically for paintball.
4. While pointing the paintball marker in a safe direction, remove the barrel blocking device and move the safety to the fire position by pushing the safety from right to left looking down the sights.
5. Point the marker over the chronograph and in a safe direction.
6. Pull the trigger and observe the reading on the chronograph.
7. To increase the velocity, turn the Velocity Adjuster (12) clockwise.
8. To decrease the velocity, turn the Velocity Adjuster counter-clockwise.
9. Once the desired velocity has been reached, use the 5/64 hex key (not provided) to turn the Velocity Set Screw in until it binds against the Rear Plug. This will prevent the velocity adjuster from moving during play and is required on most competition.
10. Re-install the Barrel Blocking Device and place the marker on "Safe".
11. Proceed to playing field.
12. Keep the safety in the "Safe" position and barrel blocking device in place until ready to play.

### De-Gassing

1. Make sure that you and anyone within range is wearing eye protection designed specifically for paintball.
2. Set the safety the "Safe" position.
3. Point the marker in a safe direction.
4. If you are using a motorized feeder, turn it off.
5. Twist the upper thumb screw on the straight elbow until loose.
6. Invert the marker so that the hopper/feeder is upside down so that paintballs are no longer feeding into the marker.

7. Remove the hopper/feeder from the marker.
8. Twisting the barrel in a counter-clockwise direction, remove it from the marker.
9. While pointing the paintball marker in a safe direction, push safety to the fire position.
10. Pull the trigger and allow the marker to cycle to confirm the absence of paintballs in the marker's breach. If a ball discharges, repeat until no more paintballs come out of the marker.
11. Unscrew the propellant cylinder approximately one complete revolution.

**⚠ WARNING:** When removing the cylinder from the marker, it could fly off with enough force to kill if the valve unscrews from the cylinder. LOOK at valve when removing cylinder. STOP if valve starts to unscrew from the tank. Screw it back on and take it to a trained person for repair.

12. Pull the trigger until the marker fails to recock (if this takes more than 10 shots, unscrew the cylinder an additional turn and repeat).
13. Remove (See Warning Above) the propellant cylinder.

## **Maintenance**

**⚠ WARNING:** All maintenance should be performed with an unloaded and degassed marker.

### Bolt & Hammer

1. De-gas the marker according to previous directions.
2. Always perform maintenance over a smooth work surface. This will help prevent the accidental loss of small parts.
3. Make sure bolt is in the forward position before proceeding.
4. Remove the Quik Strip Pin Retainer (5A) from the Quick Strip Pin (5).
5. Remove the Quik Strip Pin.
6. Remove Hammer Plug (24) from rear of main body.
7. Pull Bolt (28) from rear. This will also remove the Spring Strut (4), Main Spring (2), Recoil Pad (3) and Hammer (1).
8. Clean the bolt thoroughly to include rinsing in warm water if needed.
9. Lubricate the Bolt and Hammer with non-corrosive lubricant such as Empire Lube or Empire Oil.
10. Place the Bolt's Connecting Pin (28A) into the hole on top of the Hammer and while pointing the marker downward guide this assembly in to the rear of the Main Body.
11. The Hammer will likely stop when it makes contact with the top of the Sear (37).
12. While putting slight pressure on the rear of the bolt, pull the trigger (this depresses the Sear and allows the Bolt/Hammer assembly to travel forward).
13. Return the Main Spring, Recoil Pad and Spring Strut to their proper position.
14. Place the Hammer Plug into the rear of the Main Body with the longest portion over the Main Spring/Spring Strut.
15. Push the Hammer Plug in and replace the Quik Strip Pin.
16. Replace the Quik Strip Pin Retainer.

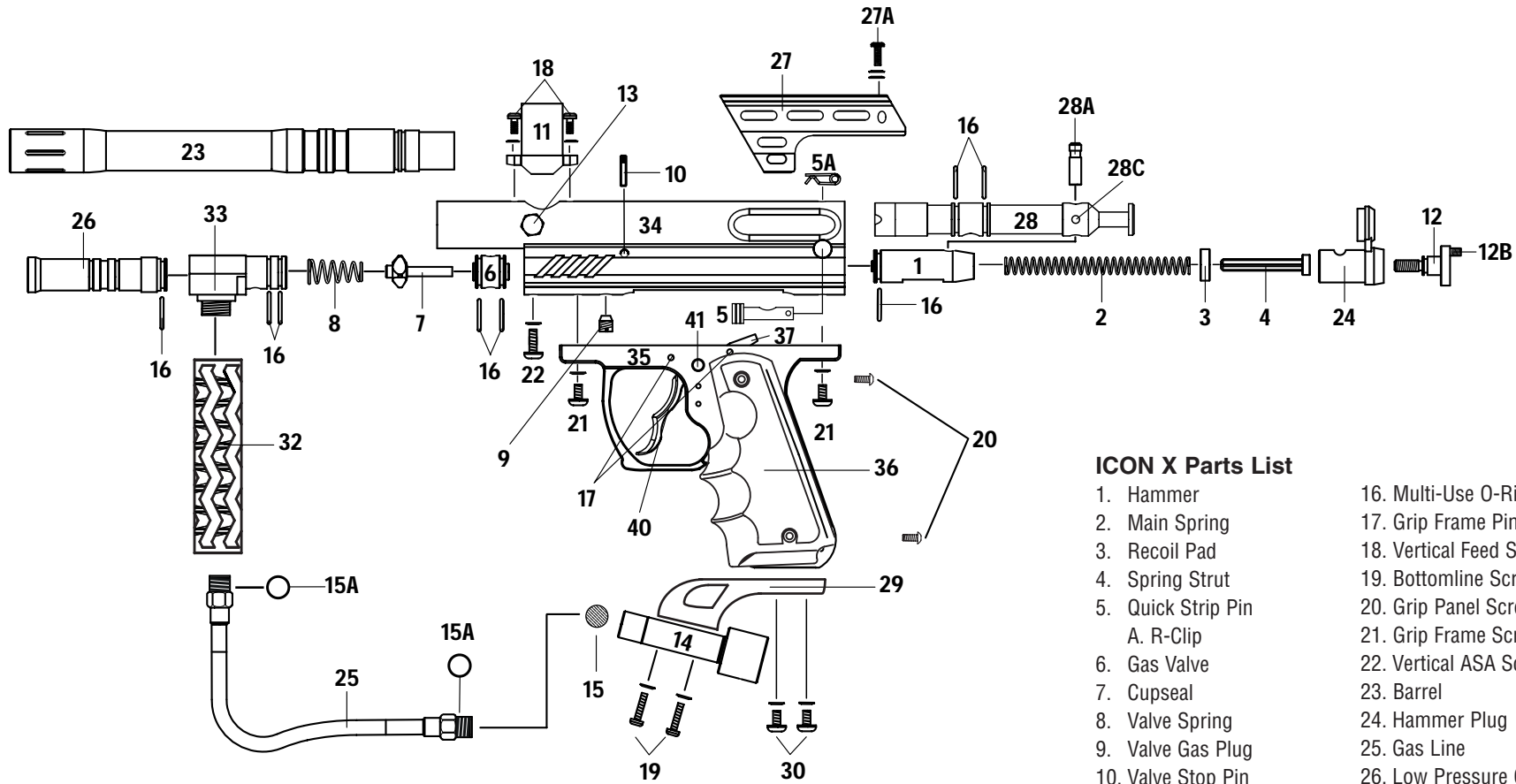

### ICON X Parts List

- |                        |                          |                         |
|------------------------|--------------------------|-------------------------|
| 1. Hammer              | 16. Multi-Use O-Ring     | 30. Drop Forward Screws |
| 2. Main Spring         | 17. Grip Frame Pin Set   | 32. Gas-Thru            |
| 3. Recoil Pad          | 18. Vertical Feed Screws | 33. Vertical ASA        |
| 4. Spring Strut        | 19. Bottomline Screws    | 34. Main Body           |
| 5. Quick Strip Pin     | 20. Grip Panel Screws    | 35. Grip Frame          |
| A. R-Clip              | 21. Grip Frame Screws    | 36. Grip Panels         |
| 6. Gas Valve           | 22. Vertical ASA Screw   | 37. Sear                |
| 7. Cupseal             | 23. Barrel               | *38. Sear Spring        |
| 8. Valve Spring        | 24. Hammer Plug          | 40. Trigger             |
| 9. Valve Gas Plug      | 25. Gas Line             |                         |
| 10. Valve Stop Pin     | 26. Low Pressure Chamber |                         |
| 11. Vertical Feed Neck | 27. Sight Rail           |                         |
| 12. Velocity Adjuster  | A. Sight Rail Screw      |                         |
| 13. Metal Ball Detent  | 28. Bolt                 |                         |
| 14. Tank Adapter       | A. Connecting Pin        |                         |
| 15. Air Filter         | C. Connecting Pin Set    |                         |
| A. Hose Fitting O-Ring | 29. Drop Forward         |                         |



\*Not Shown In Schematic



### Storage

Always set maker on "Safe", remove the hopper/feeder, all paintballs and propellant source and place it in a secure location where it cannot be accessed by unauthorized persons.

### Trouble Shooting Guide

<u>Symptom</u>	<u>Cause</u>	<u>Cure</u>
Does not Fire	Not Cocked	Cock the Bolt to the rear
	On "Safe"	Push Safety to Fire Position
	Out of Gas	Refill or Replace Propellant Source
Leaks air down Barrel	Bad Cup Seal	Replace Cup Seal
	Not Cocked	Cock the Bolt to the rear
Leaks air from ASA/Bottle Interface	Bad Bottle O-Ring	Replace Bottle O-Ring
Does not Re-cock	Low on Gas	Refill or Replace Propellant Source
	Bad Hammer	Replace Hammer
	Needs Lubrication	Lubricate Hammer and Bolt
	Debris around Bolt	Remove Bolt and clean Bolt and Breach
Goes "Full Auto"	Sear not catching	Tighten Grip Frame Screws (32)
	Low on Gas Propellant Source	Refill or Replace
	Bad Hammer	Replace Hammer
	Needs Lubrication	Lubricate Hammer and Bolt
Excessive Ball Breakage	Low Quality Paintballs	Use better Paintballs Such as Diablo Brand
	Ball Chopping	Use motorized feeder Such as Diablo TSA

When in doubt, thoroughly clean and lubricate the marker. Many marker function problems are caused by excessive dirt or lack of lubrication.

For further assistance go to [www.paintballsolutions.com](http://www.paintballsolutions.com)

### Warranty Registration

To assist us in providing the best customer service possible and to increase your warranty from 90 days to one year at no additional cost Complete and mail this to:

Paintball Solutions  
570 Mantua Blvd.  
Sewell, NJ 08080

Or register online at [www.PaintballSolutions.com](http://www.PaintballSolutions.com)

**Marker Type: Icon X**

Name: \_\_\_\_\_

Address: \_\_\_\_\_  
\_\_\_\_\_

City: \_\_\_\_\_ State: \_\_\_\_\_ Zip: \_\_\_\_\_

Country: \_\_\_\_\_

Email Address: \_\_\_\_\_

Serial Number (located on left side of marker): \_\_\_\_\_

Date of Purchase: \_\_\_\_\_

Place of Purchase: \_\_\_\_\_