

THUNDER CAT™

INSTRUCTION MANUAL

Version 1.4

Copyright 1993 - 1997 by Indian Creek Design, Inc.

All Rights Reserved

No part of this document may be copied or reproduced in any form or by any means without the prior written consent of Indian Creek Design, Inc.

Trademark Notices:

- * *Panther VTS* is a registered trademark of Indian Creek Design, Inc.
- * *Panther II VTS* is a trademark of Indian Creek Design, Inc.
- * *Puma* is a trademark of Indian Creek Design, Inc.
- * *Bobcat* is a trademark of Indian Creek Design, Inc.
- * *Desert FOX* is a trademark of Indian Creek Design, Inc.
- * *Thunder CAT* is a trademark of Indian Creek Design, Inc.
- * *45/68 Magnum VTS* is a trademark of Indian Creek Design, Inc.

Notice is hereby given that this manual is part of the article owned in whole by Indian Creek Design, Inc., known as indicated in this manual and drawings. All rights of manufacture and reproduction of such articles or any part thereof are reserved by Indian Creek Design, Inc. Neither said article nor any part thereof may be manufactured or reproduced except by written authorization from Indian Creek Design, Inc. All proprietary rights and information are the sole property of Indian Creek Design, Inc.

STATEMENT OF LIABILITY

This air gun is delivered by **Indian Creek Design, Inc.**, with the understanding that **Indian Creek Design, Inc.**, assumes no responsibility for its resale or safe handling. It can be considered a dangerous weapon if mishandled, abused, or the safety instructions are ignored. **Indian Creek Design, Inc.**, assumes no responsibility for physical injury or property damage resulting from its use.

Indian Creek Design, Inc., makes no warranties with respect to this documentation and disclaims any implied warranties of merchantability or fitness for a particular purpose. The information in this document is subject to change without notice. **Indian Creek Design, Inc.**, assumes no responsibility for any errors that may appear in this document.

This air gun is not a toy. It is to be used by adults only. It is to be used on safety certified fields only. Obey all local, state and federal laws. Follow the rules of safe paintball gun handling. Read all instructions before use.

Thunder CAT OVERVIEW

The *Thunder CAT* is a quality marking instrument specially designed to meet the needs of the professional style tournament player. The *Thunder CAT* is a semi-automatic, open bolt, blowback-type marking device. The major components of the *Thunder CAT* are machined from solid, aircraft-grade aluminum, then hard anodized per military specifications. No castings or extrusions are used in the construction of the *Thunder CAT*. No welds or epoxies are used to fill or block holes, thereby providing the end user with a high-quality, precision-engineered marking instrument.

Semi-automatics take a great pounding. Indian Creek Design, Inc., has built the *Thunder CAT* with this in mind. There are no hot welds to distort or cold welds to crack along joints and air lines. All internal parts, wear and contact surfaces have been heat treated or hard anodized. The hardest and most resilient materials have been used in the design of this instrument. But keep in mind: even jack hammers need care and maintenance.

The *Thunder CAT* does not need tools to be field-stripped. Removing the cocking-lug and the rear plug enables the removal of the entire bolt assembly. The barrel extension is removed with 1 and ½ revolutions of the barrel.

The *Thunder CAT* offers the ultimate in gas efficiency and usage. Gas usage and mainspring tension are the means of adjustment. Gas usage is controlled by two adjustment screws on the side of the gun marked RECOCK and VELOCITY. The unique feature of this gun is the RECOCK adjustment. This allows precise adjustment for the recocking of the gun for both speed and gas efficiency.

The *Thunder CAT* comes with a removable barrel system. This feature allows the user to select a barrel that is most suitable for the playing conditions. All barrels are mirror-honed and stock length is 10". All barrels are interchangeable with the *Desert Fox*, *Puma* and *Bobcat* Paintball Guns.

OPERATION

Read the entire manual before you prepare your *Thunder CAT* for firing. Safety and safe gun handling are the most important aspects of paintball sports. Please practice each of the following steps with an **unloaded** gun before attempting to charge your gun with CO2 and paint pellets. Do not load CO2 or paintballs into your *Thunder CAT* until you feel completely confident with your ability to handle your *Thunder CAT* safely.

Keep your finger out of the trigger guard and away from the trigger. Point the muzzle of the gun in a safe direction at all times. Keep the gun in "SAFE" mode until ready to operate. Push the safety button into the safe position. This will prevent the trigger from traveling its full range.

NEVER depend entirely upon your mechanical safety! ALWAYS KEEP YOUR *Thunder CAT* POINTED IN A SAFE DIRECTION. ALWAYS USE A BARREL PLUG.

CO2 Usage

The *Thunder CAT* uses CO2 as a propellant. The *Thunder CAT* uses industry standard CO2 bottles or cartridge adaptors.

Consult the place where you purchased your *Thunder CAT* or a recognized and competent airsmith for instruction in the safe handling of CO2 cylinders before purchasing or connecting one to your *Thunder CAT*.

Before pressurizing your *Thunder CAT* with CO2, check to make sure that you have pulled the cocking lug back until it locks into position. If this is not done, the CO2 might leak or hiss down the barrel. The CO2 tank can now be threaded into the tank adaptor. After screwing in the CO2 bottle, the gun is pressurized and ready to be fired! To depressurize, unscrew the CO2 bottle from the gun.

Paintball and Loader Usage

The *Thunder CAT* comes equipped to accept 7/8" OD, standard-gravity feed loaders and elbows. Fit the elbow over the direct feed. Always twist it down in a CLOCKWISE direction. Always twist it off in a CLOCKWISE direction as well. The *Thunder CAT* uses .68 caliber, water-soluble paint pellets. The pellets are gravity fed from the loader through the direct-feed nipple and into the breech of the gun. Incorporated into the direct feed is what has become known as a POWER FEED. Thanks to AIRGUN DESIGNS for originating the use of this type of device.

Firing the *Thunder CAT*

Keep your finger out of the trigger guard and away from the trigger. Point the muzzle of your gun in a safe direction during this process. Push the safety button into the safe position.

Always keep your *Thunder CAT* pointed in a safe direction!

1. Place the empty loader and elbow onto the gun. Be sure that it is securely mounted in place.
2. Pull the cocking lug back until it locks into position.
3. Screw the CO2 bottle into place, pressurizing the gun.
4. Put the paintballs into the loader.
5. Remove the barrel plug.
6. Aim the gun at the target.
7. Remove the safety by pushing the "push to fire" button.
8. Place your finger on the trigger.
9. Pull the trigger with a smooth squeezing motion. BANG. . . .

Unloading the *Thunder CAT*

Keep your finger out of the trigger guard and away from the trigger. Point the muzzle of your gun in a safe direction during this entire process.

Always keep your *Thunder CAT* pointed in a safe direction!

1. Push the safety button into the safe position.
2. Place the barrel plug into the end of the barrel.
3. Remove the CO2 bottle by unscrewing it carefully.
4. Tilt the gun so that the loader is lower than the body of the gun.
5. Remove the paintball loader from the direct-feed tube, turning the elbow in a clockwise direction.
6. Inspect the inside of the direct-feed tube to be sure that a ball does not remain inside the breech.

MAINTENANCE

CAUTION: Before attempting to perform any maintenance operations or any gun disassembly, make sure that all paint pellets and sources of CO2 have been removed from the gun. Insert a barrel plug, push the safety button to the safe position and keep the gun in its "SAFE" mode.

Simple Maintenance

Keep your *Thunder CAT* clean and lubricated to eliminate the friction that prevents reliable operation. Clean and lube the gun before each use. Do not put it away dirty. Do *not* use petroleum-based lubricants in the lubrication of this gun. Teflon or silicon spray lubricants are the recommended types for the lubrication of the *Thunder CAT*.

Cleaning Paint from the Barrel

Unscrewing the barrel with approximately one and one half (1&1/2) revolutions will enable the barrel to be removed for swabbing/cleaning. It is very important that you keep the barrel clean for the continued accuracy of the *Thunder CAT*. Gelatin from the paintballs has a tendency to build up in the barrel. In your cleaning ritual, include washing out the barrel with hot soapy water and rinsing well.

Removing the Bolt Assembly (Field Stripping)

Remove the paint and CO2 from the gun. The gun *cannot* be field stripped while it is pressurized with CO2.

1. With slight resistance on the cocking lug, pull the trigger and allow the bolt to move to the uncocked position.
2. Unscrew the rear plug and remove it along with the main spring.
3. Pull the bolt back via the cocking lug and remove the cocking lug.
4. Point the barrel upward as if to pour the bolt out of the gun. A slight tap on the back of the gun with the palm of your hand may be required to completely remove the bolt.

Once the bolt assembly is removed, it is possible to clean the entire upper receiver of the gun, including the breech and feed tube area. Lubricate the rear section of the bolt and the rear-bolt chamber with a light synthetic liquid or spray lubricant before re-installing the bolt. Do *not* use petroleum-based lubricants! Use Teflon or silicon-based lubricants.

1. Point the barrel downward and push the bolt in until it stops. At this point the bolt will not be completely inside the gun.
2. Apply pressure on the back of the bolt and pull the trigger. At this point the bolt should slide in all the way.
3. Screw the cocking lug into place.
4. Push the bolt via the cocking lug all the way forward.
5. Replace the main spring and rear plug.

STORAGE AND TRANSPORTATION

- Your *Thunder CAT* must be clear of all paint and CO2 when not being used.
- Keep the safety on.
- Put the barrel plug in place.
- Make sure the gun is clean.
- Store your *Thunder CAT* in a clean, cool, dry place.
- Keep your *Thunder CAT* away from children.

THIS AIR GUN IS NOT A TOY! TO BE USED BY ADULTS ONLY!

Your *Thunder CAT* must be clear of all paint and CO2 during transportation to and from the playing field. Keep your barrel plug in place. Keep the safety on. Protect your *Thunder CAT* from excessive heat during transportation. Observe and obey all local, state and federal laws concerning the transportation of paintball guns. For information concerning any of the laws in your area, contact the IPPA or your nearby friendly law enforcement agency.

IMPORTANT: Never carry your *Thunder CAT* un-cased when not on a playing field. The non-playing public and law enforcement personnel may not be able to distinguish between a paint marking device and firearm. For your own safety and to protect the image of the sport, always carry your *Thunder CAT* in a suitable gun case or in the box in which it was shipped.

If you must ship your *Thunder CAT* for any reason, the box in which you purchased the gun is acceptable to all major carriers. Never ship charged CO2 containers.

Thunder CAT TUNING GUIDE Version 1.2

The *Thunder CAT* has a totally new and innovative valving system that allows the independent control of the projectile velocity and the independent control of the re-cocking gas flow. This ability to control each system separately allows the operator to tune the gun to its maximum efficiency.

This tuning is accomplished by the mainspring tension-adjustment screw and two screw-type adjustments on the side of the gun labeled RECOCK and VELOCITY. Turning of the screws is done by using a 3/16 Allen wrench on the mainspring tension screw and a 5/64 Allen wrench inserted into the recock or velocity screw.

Turning the screw clockwise on the mainspring tension screw increases the mainspring tension and increases the velocity and the recock gas expulsion. Turning the mainspring tension screw counterclockwise decreases the tension on the mainspring and decreases the inertia gained by the hammer. The hammer strikes the poppet valve with less pressure, which decreases the gas flow, which in turn decreases the velocity and/or the recocking action.

Turning the VELOCITY or RECOCK adjustment screws in the clockwise direction restricts the gas flow to either the velocity or recock. Turning the screw counterclockwise increases gas flow, thus increasing the gas used to propel the paintball or the recocking action. These adjustment screws labeled VELOCITY and RECOCK are used to **balance** the use of the gas for performing each certain function. Too much of one or the other will throw the system out of balance and the gun will not function as it was designed to function.

Think of the *Thunder CAT* as a car for a moment and the two screws on the side as adjusting the carburetor. The two screws would adjust your air jet and your gas jet and therefore how the car operates and how efficient it works. These side screws are there so players can fine tune their gun for their particular area, climate and style of play.

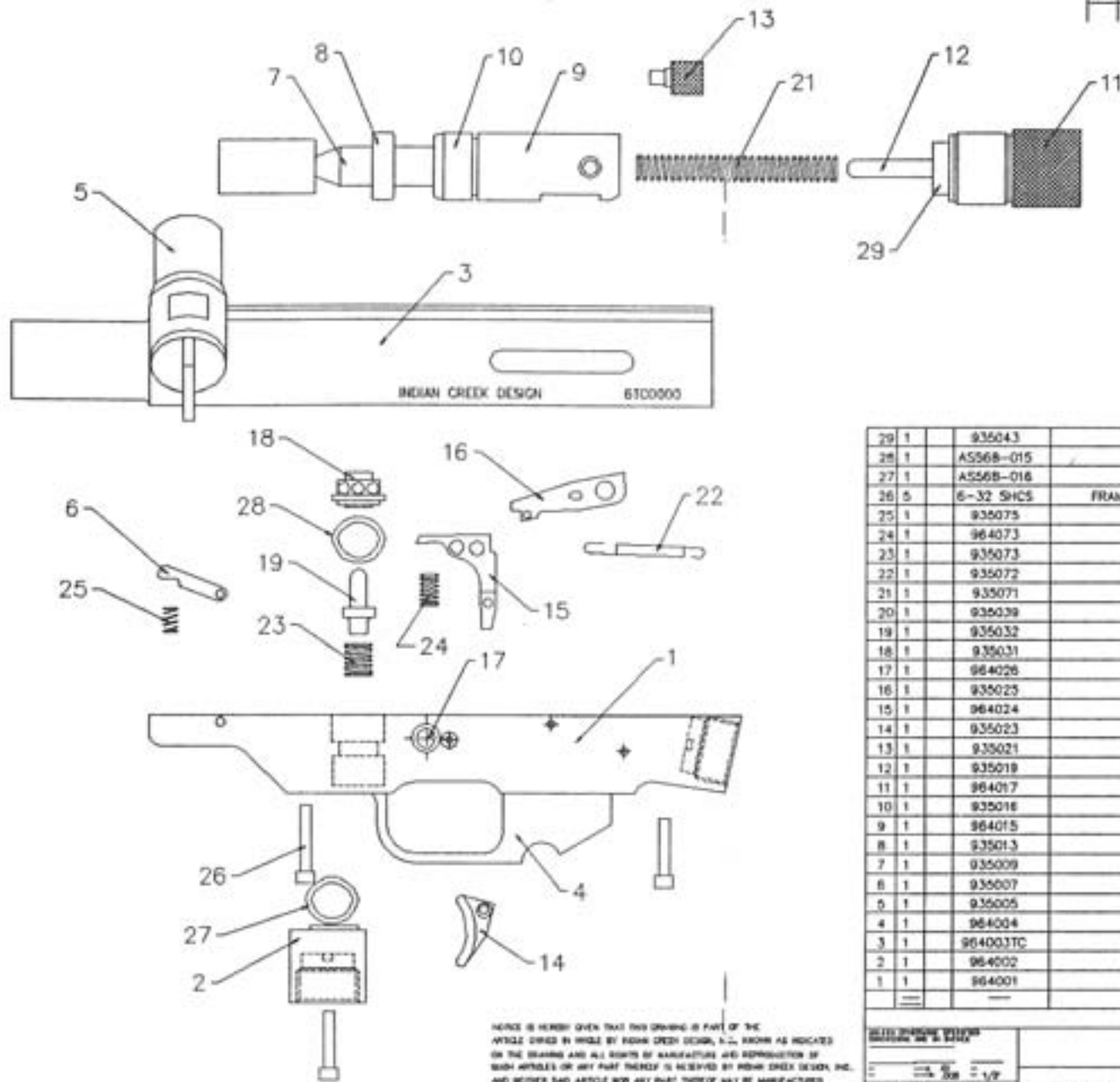

REV	DESCRIPTION	DATE	APPROVED

29	1	935043	REAR BUMPER	70 DURO BUNA
28	1	A5268-015	-015 O'RING	NITRIL
27	1	A5268-016	-016 O'RING	NITRIL
26	5	6-32 SHCS	FRAME SCREWS, SOCKET HEAD 6-32	QEN
25	1	935075	BALL RETENSION SPRING	ST STL
24	1	964073	TRIGGER SPRING, TCAT	ST STL
23	1	935073	VALVE SPRING	ST STL
22	1	935072	SEAR SPRING	MUSIC WIRE
21	1	935071	MAIN SPRING	ST STL
20	1	935039	TANK ADAPTER PLUG	DELFRN
19	1	935032	VALVE PIN ASSY	
18	1	935031	VALVE SEAT	6061-T6
17	1	964026	SAFETY	303 QRES
16	1	935025	SEAR	4130 CARBURIZED
15	1	964024	TRIGGER ARM	4130 HT 54 Rc
14	1	935023	TRIGGER SHOE	6061-T6
13	1	935021	COCKING LUG	6061-T6
12	1	935019	SPRING GUIDE	6061-T6
11	1	964017	END PLUG	DELFRN
10	1	935016	HAMMER ROLLER	D-1 HT 64Rc
9	1	964015	HAMMER, TCAT	4340 HT
8	1	935013	CENTER BUSHING	DELFRN
7	1	935009	BOLT TIP	DELFRN
6	1	935007	BALL RETENTION LEVER	6061-T6
5	1	935005	POWER FEED TUBE	6061-T6
4	1	964004	TRIGGER GUARD	6061-T6
3	1	964003TC	UPPER RECEIVER, TCAT	6061-T6
2	1	964002	VERTICAL TANK ADAPTER	6061-T6
1	1	964001	LOWER RECEIVER	6061-T6

HEREBY IS HEREBY GIVEN THAT THIS DRAWING IS PART OF THE ARTICLE DESIGNED BY INDIAN CREEK DESIGN, S.L., KNOWN AS INDICATED ON THE DRAWING AND ALL RIGHTS OF MANUFACTURE AND REPRODUCTION OF SUCH ARTICLES OR ANY PART THEREOF IS RESERVED BY INDIAN CREEK DESIGN, INC. AND NEITHER SAID ARTICLE NOR ANY PART THEREOF MAY BE MANUFACTURED OR REPRODUCED EXCEPT BY WRITTEN AUTHORIZATION FROM INDIAN CREEK DESIGN, INC. ALL PROPRIETARY RIGHTS AND INFORMATION ARE THE SOLE PROPERTY OF INDIAN CREEK DESIGN, INC.

INDIAN CREEK DESIGN DESIGNING & DRAWING		INDIAN CREEK DESIGN, Inc.	
SCALE: 1/8" = 1"		Thunder CAT	
DATE: 05-11-98	BY: [Signature]	REV: 0	REV: B
DO NOT SCALE DRAWING		SCALE: 1/8" = 1" SHEET 1 OF 1	

GETTING STARTED

Start with a full tank of CO2, a chronograph, and the paintball of your choice--and of course your goggles on your face:

1. Before installing the paintballs or the tank, push the safety button in to lock the trigger. Cock the gun by pulling the cocking lever toward the back of the gun until it clicks into place.
2. Using the 5/64 Allen wrench, close the recocking valve by turning the screw clockwise until it stops. Now turn counterclockwise 1 turn. If you are attempting to use a siphon tank system, start with the recock adjustment screw turned clockwise until it stops (shut-off).
3. Using the 5/64 Allen wrench, close the velocity valve by turning the screw clockwise until it stops. Now turn counterclockwise two and one half to three turns.
4. Using the 3/16 Allen wrench, back off the main-spring tension screw by turning it counterclockwise until the face of the screw is flush with the face of the end plug.

(This starting position for the adjustment screws is the intermediate position.)

5. With the gun pointed in a safe direction, follow the tank insertion guidelines in the CO2 usage section of this manual and screw the tank into the adaptor.
6. Drop one (1) paintball into the feed tube.
7. Aim the gun over the chronograph.
8. Remove the safety by pushing the fire button.
9. Pull the trigger to shoot the paintball, and check the velocity and recock action. Use the mainspring tension screw to achieve the desired velocity by increasing or decreasing the tension of the main spring. Under normal circumstances the velocity and recocking jets should not have to be further adjusted once Step 2 has been done. Repeat Steps 6-9 until the desired velocity is reached.
10. Push the safety button in to lock the trigger and place your paintball feed system onto the feed tube.

NOTE 1. This gun was not designed to be a jack-hammer. The lighter the mainspring tension is, the more reliable and more consistent the gun will be--not to mention the longer life that will be obtained on all the parts of the gun. High mainspring tension, coupled with the VELOCITY jet being screwed in or all the way out, and the RECOCK jet screwed all the way out, will result in the premature deterioration of the gun, poor performance and efficiency, and a very disappointing day. Remember. You are shooting gelatin capsules filled with paint--not shattering concrete or driving 16-penny nails!

NOTE 2. Under normal circumstances, the RECOCK valve should never be adjusted more than 1/4 of a turn from being all the way in! Damage to the upper receiver housing may occur.

NOTE 3. This gun is not designed to shoot above the safety limits established by industry standards.

GENERAL NOTES

1. Once the velocity adjustment screw is turned clockwise all the way, it only functions for six turns in the counterclockwise direction. Although it may turn more than six revolutions, it only functions for the first six revolutions.
2. Once the recock adjustment screw is turned clockwise all the way, it only functions for one and a half (1&1/2) turns maximum in the counterclockwise direction. Although it may turn more than one and a half revolutions, it only functions for the first one and a half revolutions. **Under normal circumstances the RECOCK valve should never be adjusted more than 1 1/2 turns from being all the way in!**

If either of the screws protrudes out of the side of the gun, they have been turned out too far and have lost their ability to affect the performance of the gun, and it is possible that they could fall out of the gun. If the VELOCITY jet and the RECOCK jet are screwed all the way out, then your mainspring tension adjustment is probably screwed all the way in. This will result in the premature deterioration of the gun, poor performance and efficiency (if it works at all), and a very disappointing day. Go back to GETTING STARTED. Remember, you are shooting gelatin capsules filled with paint, not shattering concrete or driving 16-penny nails!

If opening the jets all the way is the only way that you can make the gun function--something is wrong! Call **Indian Creek Design, Inc.**, at (208)468-0446 before proceeding further.

TROUBLE SHOOTING

Recocking Related Problems

1. **The gun does not recock when you pull the trigger; it shoots and sticks forward.**
 - a. The pressure in the tank is low.
 - b. The pressure in the tank may be too high.
 - c. Needs lubrication in the hammer-slide chamber.
 - d. Open the recock valve, 1/4 turn at a time--but *never more than 1 1/2 total turns*.
 - e. The hammer/bolt assembly is dragging and the inertia that it takes to open the poppet valve is lost.
2. **The gun does not recock when you pull the trigger; it shoots and pounds down (does not come back all the way).**
 - a. The pressure in the tank is low. A freshly filled CO2 tank that is cold or frozen will give this result.
 - b. Needs lubrication in the hammer-slide chamber.
 - c. Open the recock valve, 1/4 turn at a time--but *never more than 1 1/2 total turns!*
 - d. The hammer/bolt assembly is dragging and the inertia that it takes to open the poppet valve is lost.
 - e. Main spring tension may be too high. Back it off and re-tune the gun per GETTING STARTED.

3. **The gun does recock, but when you pull the trigger, it shoots and bounces (double fires) before recocking (breaks paintballs in the breach and sends paint back up into the feed tube).**
 - a. Too much gas is being expelled to the recock chamber. This is often the case, especially when using a siphon tank system. If using a siphon tank, turn the RECOCK screw all the way in (shut-off).
 - b. The pressure in the tank is high or the pressure may be too low to operate the gun.
 - c. Close the recock valve and reopen the recock valve, 1/4 turn at a time--but **never more than 1 1/2 total turns!**
 - d. Hammer and sear contact points may have worn and need replacing.
 - e. Main spring tension may be too high. Back it off and re-tune the gun per GETTING STARTED.

Leak Related Problems

1. **The Thunder CAT has a leak down the barrel. Reason: CO2 is leaking through or around the valve area.**
 - a. Can you hear the leak when the CO2 is removed? Yes? There is no leak. You hear the ocean.
 - b. CO2 bottle has no gas left and there is not enough pressure to keep the cup seal closed.
 - c. The cup seal is marred/scratched or worn out or dirt has gotten to it. Replace it.
 - d. The O-ring for the valve seat has been removed and not replaced.
 - e. The sealing surface on the valve seat or seal is scratched or gouged. Replace the valve seat or seal.
 - f. When you rebuilt the gun, you placed the valvepin or the valve seat in upside-down.

Ball Breakage Problems

1. **The paintballs break in the barrel.**
 - a. Change paintballs. The gelatin that paintballs are made from can lose its elasticity with age, making the shell of the paintball brittle and not able to withstand the shock of the blast of CO2 when shot.
 - b. Rebalance your CO2 usage by re-tuning the VELOCITY and RECOCK adjustments.
2. **The ball breaks in the breach.**
 - a. The balls in your loader can bind, messing up your trigger timing. Note the ball drop through your elbow.
 - b. As you run and shoot, you actually unweigh the gravity-fed balls in your loader. This can cause a ball to hesitate in its drop. This affects your trigger timing.
 - c. If the ball retention arm does not move freely, the paintballs will crush against the arm or the arm may have stuck in the depressed position, allowing double feeding. Check its tension regularly and keep this area as clean as possible.
 - d. If the ball retention arm is too sloppy, the ball will not be held in the proper position. This may allow the next ball to enter the path of the bolt, subjecting it to impact cracking or shearing. Verify the spring tension.
 - e. Rebalance your CO2 usage by re-tuning the VELOCITY and RECOCK adjustments. (REFER TO TUNING GUIDE)

If your gun is out of tune and will not do anything but break paint, stutter and chatter, go back to GETTING STARTED, Steps 1 through 4.